



BSI Standards Publication

Organization and digitization of information about buildings and civil engineering works, including building information modelling (BIM) - Information management using building information modelling

Part 2: Delivery phase of the assets

National foreword

This British Standard is the UK implementation of EN ISO 19650-2:2018. Together with BS EN ISO 19650-1:2018, it supersedes BS 1192:2007+A2:2016 and PAS 1192-2:2013, which are withdrawn.

It contains clarification of clauses within ISO 19650 in relation to the following documents, some of which are expected to be withdrawn and superseded during the life of this document:

- | | |
|----------------------------|---|
| BS 1192 | <i>Collaborative production of architectural, engineering and construction information - Code of practice</i> |
| PAS 1192-2 | <i>Specification for information management for the capital/delivery phase of construction projects using building information modelling</i> |
| PAS 1192-3 | <i>Specification for information management for the operational phase of assets using building information modelling</i> |
| BS 1192-4 | <i>Collaborative production of information Part 4: Fulfilling employer's information exchange requirements using COBie – Code of practice</i> |
| PAS 1192-5 | <i>Specification for security-minded building information modelling, digital built environments and smart asset management</i> |

The UK participation in its preparation was entrusted to Technical Committee B/555, Construction design, modelling and data exchange.

A list of organizations represented on this committee can be obtained on request to its secretary.

The UK committee draws users' attention to the [National Annex NA](#), which provides further guidance to assist users in the application of this standard.

This publication does not purport to include all the necessary provisions of a contract. Users are responsible for its correct application.

© The British Standards Institution 2019
Published by BSI Standards Limited 2019

ISBN 978 0 580 92467 5

ICS 35.240.67; 91.010.01

Compliance with a British Standard cannot confer immunity from legal obligations.

This British Standard was published under the authority of the Standards Policy and Strategy Committee on 31 January 2019.

Amendments/corrigenda issued since publication

Date	Text affected
------	---------------

EUROPEAN STANDARD

EN ISO 19650-2

NORME EUROPÉENNE

EUROPÄISCHE NORM

December 2018

ICS 35.240.67; 91.010.01

English Version

Organization and digitization of information about
buildings and civil engineering works, including building
information modelling (BIM) - Information management
using building information modelling - Part 2: Delivery
phase of the assets (ISO 19650-2:2018)

Organisation et numérisation des informations
relatives aux bâtiments et ouvrages de génie civil, y
compris modélisation des informations de la
construction (BIM) - Gestion de l'information par
modélisation des informations de la construction -
Partie 2: Phase de réalisation des actifs (ISO 19650-
2:2018)

Organisation von Daten zu Bauwerken -
Informationsmanagement mit BIM - Teil 2: Lieferphase
der Assets (ISO 19650-2:2018)

This European Standard was approved by CEN on 24 August 2018.

CEN members are bound to comply with the CEN/CENELEC Internal Regulations which stipulate the conditions for giving this European Standard the status of a national standard without any alteration. Up-to-date lists and bibliographical references concerning such national standards may be obtained on application to the CEN-CENELEC Management Centre or to any CEN member.

This European Standard exists in three official versions (English, French, German). A version in any other language made by translation under the responsibility of a CEN member into its own language and notified to the CEN-CENELEC Management Centre has the same status as the official versions.

CEN members are the national standards bodies of Austria, Belgium, Bulgaria, Croatia, Cyprus, Czech Republic, Denmark, Estonia, Finland, Former Yugoslav Republic of Macedonia, France, Germany, Greece, Hungary, Iceland, Ireland, Italy, Latvia, Lithuania, Luxembourg, Malta, Netherlands, Norway, Poland, Portugal, Romania, Serbia, Slovakia, Slovenia, Spain, Sweden, Switzerland, Turkey and United Kingdom.



EUROPEAN COMMITTEE FOR STANDARDIZATION
COMITÉ EUROPÉEN DE NORMALISATION
EUROPÄISCHES KOMITEE FÜR NORMUNG

CEN-CENELEC Management Centre: Rue de la Science 23, B-1040 Brussels

European foreword

This document (EN ISO 19650-2:2018) has been prepared by Technical Committee ISO/TC 59 "Buildings and civil engineering works" in collaboration with Technical Committee CEN/TC 442 "Building Information Modelling (BIM)" the secretariat of which is held by SN.

This European Standard shall be given the status of a national standard, either by publication of an identical text or by endorsement, at the latest by June 2019, and conflicting national standards shall be withdrawn at the latest by June 2019.

Attention is drawn to the possibility that some of the elements of this document may be the subject of patent rights. CEN shall not be held responsible for identifying any or all such patent rights.

According to the CEN-CENELEC Internal Regulations, the national standards organizations of the following countries are bound to implement this European Standard: Austria, Belgium, Bulgaria, Croatia, Cyprus, Czech Republic, Denmark, Estonia, Finland, Former Yugoslav Republic of Macedonia, France, Germany, Greece, Hungary, Iceland, Ireland, Italy, Latvia, Lithuania, Luxembourg, Malta, Netherlands, Norway, Poland, Portugal, Romania, Serbia, Slovakia, Slovenia, Spain, Sweden, Switzerland, Turkey and the United Kingdom.

Endorsement notice

The text of ISO 19650-2:2018 has been approved by CEN as EN ISO 19650-2:2018 without any modification.

Contents

	Page
Foreword	v
Introduction	vi
1 Scope	1
2 Normative references	1
3 Terms, definitions and symbols	1
3.1 Terms and definitions.....	1
3.1.1 General terms.....	1
3.1.2 Terms related to assets and projects.....	2
3.1.3 Terms related to information management.....	2
3.2 Symbols.....	2
4 Information management during the delivery phase of assets	3
5 Information management process during the delivery phase of assets	3
5.1 Information management process — Assessment and need.....	3
5.1.1 Appoint individuals to undertake the information management function.....	3
5.1.2 Establish the project's information requirements.....	4
5.1.3 Establish the project's information delivery milestones.....	4
5.1.4 Establish the project's information standard.....	4
5.1.5 Establish the project's information production methods and procedures.....	5
5.1.6 Establish the project's reference information and shared resources.....	5
5.1.7 Establish the project's common data environment.....	5
5.1.8 Establish the project's information protocol.....	6
5.1.9 Activities for assessment and need.....	6
5.2 Information management process — Invitation to tender.....	7
5.2.1 Establish the appointing party's exchange information requirements.....	7
5.2.2 Assemble reference information and shared resources.....	8
5.2.3 Establish tender response requirements and evaluation criteria.....	8
5.2.4 Compile invitation to tender information.....	8
5.2.5 Activities for invitation to tender.....	9
5.3 Information management process — Tender response.....	9
5.3.1 Nominate individuals to undertake the information management function.....	9
5.3.2 Establish the delivery team's (pre-appointment) BIM execution plan.....	10
5.3.3 Assess task team capability and capacity.....	10
5.3.4 Establish the delivery team's capability and capacity.....	11
5.3.5 Establish the delivery team's mobilization plan.....	11
5.3.6 Establish the delivery team's risk register.....	12
5.3.7 Compile the delivery team's tender response.....	12
5.3.8 Activities for tender response.....	12
5.4 Information management process — Appointment.....	13
5.4.1 Confirm the delivery team's BIM execution plan.....	13
5.4.2 Establish the delivery team's detailed responsibility matrix.....	13
5.4.3 Establish the lead appointed party's exchange information requirements.....	14
5.4.4 Establish the task information delivery plan(s).....	15
5.4.5 Establish the master information delivery plan.....	15
5.4.6 Complete lead appointed party's appointment documents.....	16
5.4.7 Complete appointed party's appointment documents.....	16
5.4.8 Activities for appointment.....	16
5.5 Information management process — Mobilization.....	17
5.5.1 Mobilize resources.....	17
5.5.2 Mobilize information technology.....	17
5.5.3 Test the project's information production methods and procedures.....	17
5.5.4 Activities for mobilization.....	17
5.6 Information management process — Collaborative production of information.....	18

5.6.1	Check availability of reference information and shared resources.....	18
5.6.2	Generate information.....	18
5.6.3	Undertake quality assurance check.....	19
5.6.4	Review information and approve for sharing.....	19
5.6.5	Information model review.....	20
5.6.6	Activities for collaborative production of information.....	20
5.7	Information management process — Information model delivery.....	20
5.7.1	Submit information model for lead appointed party authorization.....	20
5.7.2	Review and authorize the information model.....	20
5.7.3	Submit information model for appointing party acceptance.....	21
5.7.4	Review and accept the information model.....	21
5.7.5	Activities for information model delivery.....	21
5.8	Information management process — Project close-out.....	22
5.8.1	Archive the project information model.....	22
5.8.2	Capture lessons learned for future projects.....	22
5.8.3	Activities for project close-out.....	22
Annex A (informative) Information management assignment matrix.....		24
Bibliography.....		26

Foreword

ISO (the International Organization for Standardization) is a worldwide federation of national standards bodies (ISO member bodies). The work of preparing International Standards is normally carried out through ISO technical committees. Each member body interested in a subject for which a technical committee has been established has the right to be represented on that committee. International organizations, governmental and non-governmental, in liaison with ISO, also take part in the work. ISO collaborates closely with the International Electrotechnical Commission (IEC) on all matters of electrotechnical standardization.

The procedures used to develop this document and those intended for its further maintenance are described in the ISO/IEC Directives, Part 1. In particular, the different approval criteria needed for the different types of ISO documents should be noted. This document was drafted in accordance with the editorial rules of the ISO/IEC Directives, Part 2 (see www.iso.org/directives).

Attention is drawn to the possibility that some of the elements of this document may be the subject of patent rights. ISO shall not be held responsible for identifying any or all such patent rights. Details of any patent rights identified during the development of the document will be in the Introduction and/or on the ISO list of patent declarations received (see www.iso.org/patents).

Any trade name used in this document is information given for the convenience of users and does not constitute an endorsement.

For an explanation of the voluntary nature of standards, the meaning of ISO specific terms and expressions related to conformity assessment, as well as information about ISO's adherence to the World Trade Organization (WTO) principles in the Technical Barriers to Trade (TBT) see www.iso.org/iso/foreword.html.

This document was prepared by Technical Committee ISO/TC 59, *Buildings and civil engineering works*, Subcommittee SC 13, *Organization and digitalization of information about buildings and civil engineering works, including building information modelling (BIM)*.

A list of all parts in the ISO 19650 series can be found on the ISO website.

Any feedback or questions on this document should be directed to the user's national standards body. A complete listing of these bodies can be found at www.iso.org/members.html.

Introduction

0.1 Purpose

This document is designed to enable an appointing party to establish their requirements for information during the delivery phase of assets and to provide the right commercial and collaborative environment within which (multiple) appointed parties can produce information in an effective and efficient manner.

This document is applicable to built assets and construction projects of all sizes and all levels of complexity. This includes large estates, infrastructure networks, individual buildings and pieces of infrastructure, and the projects or programmes that deliver them. However, the requirements included in this document should be applied in a way that is proportionate and appropriate to the scale and complexity of the asset or project. In particular, procurement and mobilization of asset or project appointed parties should be integrated as far as possible with documented processes for technical procurement and mobilization.

This document makes wide use of the phrase “shall consider”, particularly in the requirements in [Clause 5](#). This phrase is used to introduce a list of items that the person in question needs to think about carefully in connection with the primary requirement described in the clause. The amount of thought involved, the time taken to complete it and the need for supporting evidence will depend on the complexity of the project, the experience of the person(s) involved and the requirements of any national policy on introducing building information modelling. On a relatively small or straightforward project, it can be possible to complete, or dismiss as not relevant, some of these “shall consider” items very quickly.

One way to help identify which of the “shall consider” statements are relevant, can be to review each statement and create templates for projects of different sizes and complexity.

This document can be used by any appointing party. If the appointing party intends this document to apply to any asset (project) this should be reflected in the appointment.

This document defines the information management process, containing the activities through which delivery teams can collaboratively produce information and minimize wasteful activities.

This document is primarily intended for use by the following (see [Figure 1](#)):

- those involved in the management or production of information during the delivery phase of assets;
- those involved in the definition and procurement of construction projects;
- those involved in the specification of appointments and facilitation of collaborative working;
- those involved in the design, construction, operation, maintenance and decommissioning of assets; and
- those responsible for the realization of value for their organization from their asset base.

This document contains the requirements associated with the management of information during the delivery phase of built assets, which will need to be reviewed and revised on a regular basis until the best practice is established.

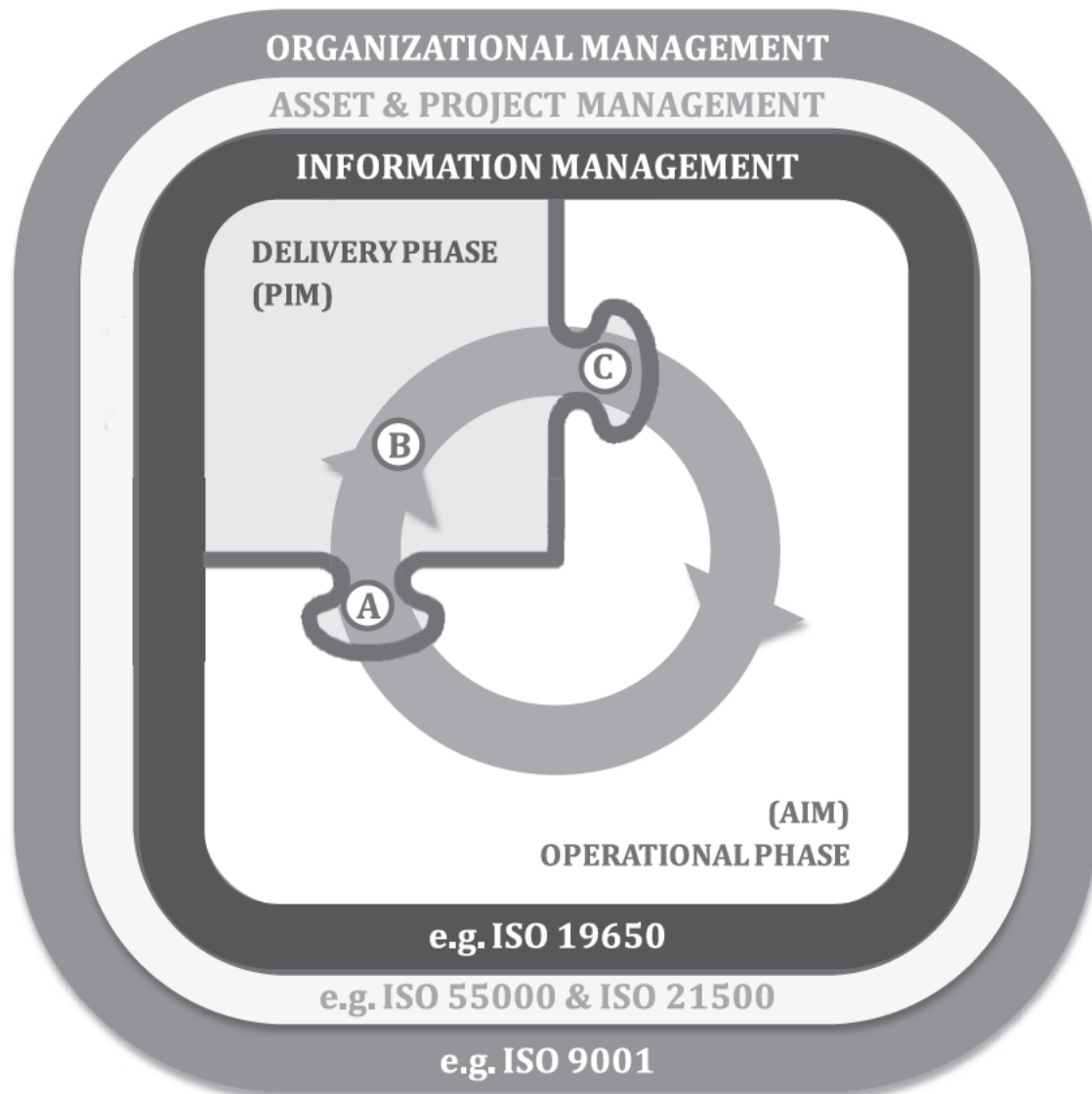

Key

AIM asset information model

PIM project information model

A start of delivery phase — transfer of relevant information from AIM to PIM

B progressive development of the design intent model into the virtual construction model

C end of delivery phase — transfer of relevant information from PIM to AIM

Figure 1 — Scope of this document

0.2 National annex with relevant national standards

There are several standards required for the successful implementation of this document, relating to specific regions or countries, that are currently not suitable for inclusion within an international standard. As such, national standards bodies are encouraged to compile and document the standards, relevant to the region or country they represent, within a national annex. National annexes can also provide localised guidance and advice on how to implement this document for projects of varying complexity.

0.3 Relationship with other standards

The concepts and principles relating to the application of the requirements within this document are provided in ISO 19650-1.

General information on asset management can be found in [ISO 55000](#).

Appointing parties can find that consideration of the concepts and principles contained within both ISO 19650-1 and [ISO 55000](#) can assist the implementation of the requirements presented in this document and development of asset management in their organization.

0.4 Benefits of the ISO 19650 series

The aim of this series is to support all parties towards achieving their business objectives through the effective and efficient procurement, use and management of information during the delivery phase of assets.

International cooperation in the preparation of these documents has identified a common information management process that can be applied to the broadest range of assets, in the broadest range of organizations, across the broadest range of cultures and under the broadest range of appointment routes.

0.5 Interfaces between parties and teams for the purpose of information management

For the purpose of this document, [Figure 2](#) shows the interfaces between parties and teams in terms of information management and should not be seen as identification of contractual relationships.

The terms for both parties and teams have been used throughout this document to identify and assign the accountable party for each sub-activity.

NOTE Delivery teams can join and leave the project team at any time.

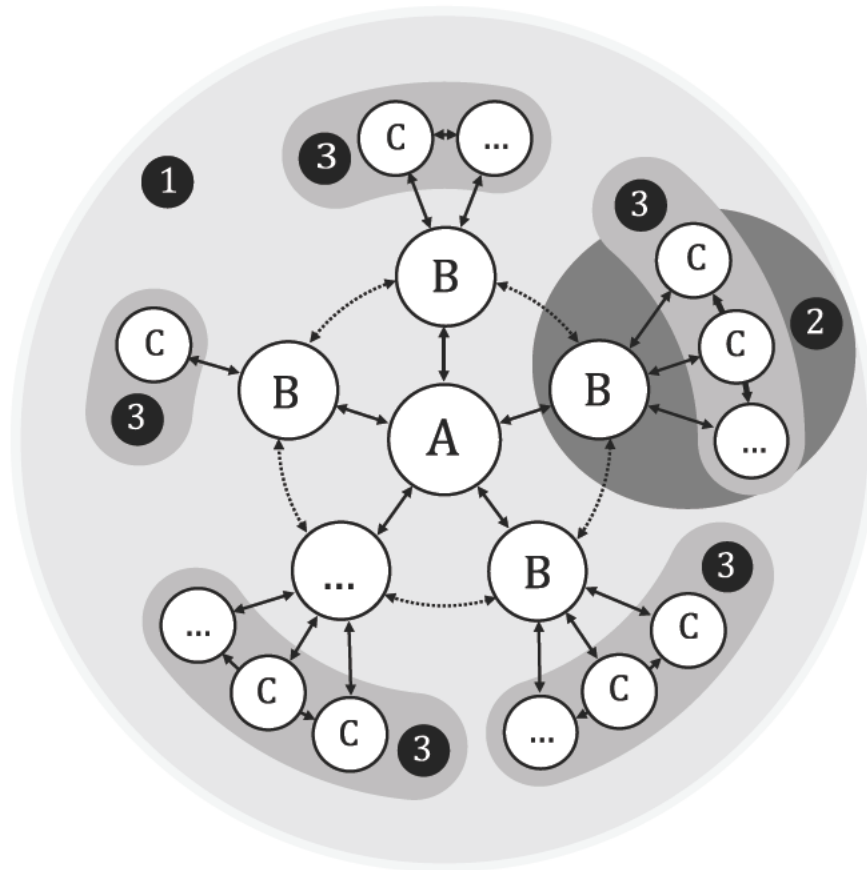

Key

- A appointing party
- B lead appointed party
- C appointed party
- ... variable amount
- 1 project team
- 2 illustration of a delivery team
- 3 task team(s)
- ↔ information requirements and information exchange
- ⋯↔ information coordination

Figure 2 — Interfaces between parties and teams for the purpose of information management

Organization and digitization of information about buildings and civil engineering works, including building information modelling (BIM) — Information management using building information modelling —

Part 2: Delivery phase of the assets

1 Scope

This document specifies requirements for information management, in the form of a management process, within the context of the delivery phase of assets and the exchanges of information within it, using building information modelling.

This document can be applied to all types of assets and by all types and sizes of organizations, regardless of the chosen procurement strategy.

2 Normative references

The following documents are referred to in the text in such a way that some or all of their content constitutes requirements of this document. For dated references, only the edition cited applies. For undated references, the latest edition of the referenced document (including any amendments) applies.

ISO 19650-1, *Organization of information about construction works — Information management using building information modelling — Part 1: Concepts and Principles*

[ISO 12006-2](#), *Building construction — Organization of information about construction works — Part 2: Framework for classification*

3 Terms, definitions and symbols

3.1 Terms and definitions

For the purposes of this document, the terms and definitions given in ISO 19650-1 and the following apply.

ISO and IEC maintain terminological databases for use in standardization at the following addresses:

- ISO Online browsing platform: available at <https://www.iso.org/obp>
- IEC Electropedia: available at <http://www.electropedia.org/>

3.1.1 General terms

3.1.1.1

acceptance criteria

evidence required for considering that requirements have been fulfilled

[SOURCE: [ISO 22263:2008](#), 2.1]

3.1.2 Terms related to assets and projects

3.1.2.1

project team

appointing party and all delivery teams

3.1.2.2

plan of work

document that details principal stages in the design, construction work and maintenance of a project and identifies the main tasks and people

Note 1 to entry: A plan of work may be extended to include the stages in demolition and recycling of a project.

[SOURCE: ISO 6707-2:2017, 3.2.19, modified — Alternative terms “staging plan, US” and “project plan, US” have been removed; Note 1 to entry has been added.]

3.1.3 Terms related to information management

3.1.3.1

BIM execution plan

plan that explains how the information management aspects of the appointment will be carried out by the delivery team

Note 1 to entry: The pre-appointment BIM execution plan focuses on the delivery team’s proposed approach to information management and their capability and capacity to manage information.

3.1.3.2

information delivery milestone

scheduled event for a predefined information exchange

3.1.3.3

master information delivery plan

MIDP

plan incorporating all relevant *task information delivery plans* ([3.1.3.4](#))

3.1.3.4

task information delivery plan

TIDP

schedule of information containers and delivery dates, for a specific task team

3.2 Symbols



start



end



collapsed sub-process



activity

NOTE the symbols used within this document have been adapted from symbols defined within [ISO/IEC 19510](#).

4 Information management during the delivery phase of assets

The information management process (Figure 3) shall be applied throughout the delivery phase for each appointment, regardless of project stage.

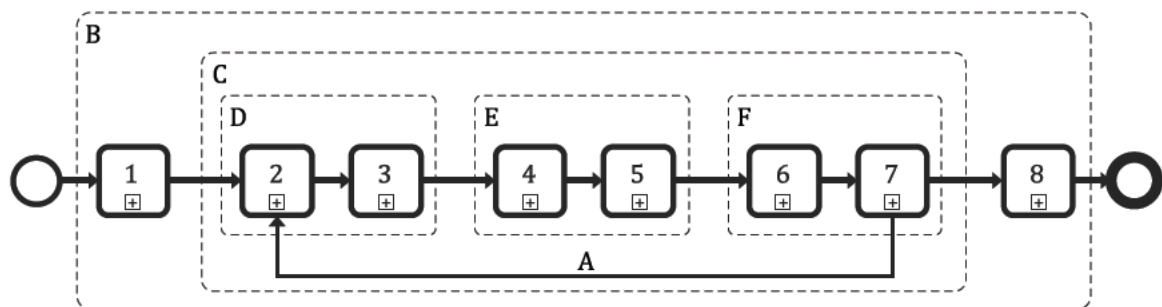

Activities

1	assessment and need	A	information model progressed by subsequent delivery team(s) for each appointment
2	invitation to tender	B	activities undertaken per project
3	tender response	C	activities undertaken per appointment
4	appointment	D	activities undertaken during the procurement stage (of each appointment)
5	mobilization	E	activities undertaken during the information planning stage (of each appointment)
6	collaborative production of information	F	activities undertaken during the information production stage (of each appointment)
7	information model delivery		
8	project close-out (end of delivery phase)		

Figure 3 — Information management process during the delivery phase of assets

NOTE 1 It is these activities that have been used as the structure for this document, in particular [Clause 5](#).

NOTE 2 The order in which activities are presented in [Figure 3](#) reflects the order in which they are undertaken.

NOTE 3 In the event that the information management process is undertaken within a single organization, the appointment can be supplemented by an internal work instruction, followed by an acceptance of the work instruction and confirmation to proceed. See ISO 19650-1:2018, 6.3 and 8.1 for more information.

5 Information management process during the delivery phase of assets

5.1 Information management process — Assessment and need

5.1.1 Appoint individuals to undertake the information management function

The appointing party shall have regard to the effective management of information throughout the project and reflect the long-term asset information management strategy, as described in ISO 19650-1:2018, 5.3, by nominating individuals from within the appointing party's organization to undertake the information management function on behalf of the appointing party.

Alternatively, the appointing party can appoint a prospective lead appointed party or a third-party to undertake all or part of the information management function, in which case, the appointing party shall establish a scope of services.

In doing this, the appointing party shall consider:

- the tasks that the prospective lead appointed party or third party will be responsible for;

- the authority that the appointing party will delegate to the prospective lead appointed party or third party; and
- the competency (knowledge or skills) that the individuals undertaking the function will need.

NOTE Where the appointing party appoints a prospective lead appointed party or a third party to undertake all or part of the information management function, the use of the information management assignment matrix ([Annex A](#)) can help with establishing the scope of services needed.

5.1.2 Establish the project's information requirements

The appointing party shall establish the project's information requirements, as described in ISO 19650-1:2018, 5.3, to address the questions to which the appointing party needs answer(s) at each of the key decision points throughout the project.

In doing this, the appointing party shall consider:

- the project scope;
- the intended purpose for which the information will be used by the appointing party;
- the project plan of work;
- the intended procurement route;
- the number of key decision points throughout the project;
- the decisions that the appointing party needs to make at each key decision point; and
- the questions to which the appointing party needs answers, to make informed decisions.

5.1.3 Establish the project's information delivery milestones

The appointing party shall establish the project's information delivery milestones in accordance with the project's plan of work.

In doing this, the appointing party shall consider:

- the appointing party's key decision points;
- its own information delivery obligations (if any);
- the nature and substance of information to be delivered at each key decision point; and
- the date(s) relative to each key decision point that the information model is to be delivered.

5.1.4 Establish the project's information standard

The appointing party shall establish any specific information standards required by the appointing party's organization within the project's information standard.

In doing this, the appointing party shall consider:

- a) the exchange of information:
 - within the appointing party's organization,
 - between the appointing party and external stakeholders,
 - between the appointing party and external operators or maintainers,
 - between the prospective lead appointed party and the appointing party,

- between prospective appointed parties on the same project, and
 - between interdependent projects;
- b) the means of structuring and classifying information;
- c) the method of assignment for level of information need; and
- d) the use of information during the operational phase of the asset.

5.1.5 Establish the project's information production methods and procedures

The appointing party shall establish any specific information production methods and procedures required by their organization within the project's information production methods and procedures.

In doing this, the appointing party shall consider:

- a) the capture of existing asset information;
- b) the generation, review or approval of new information;
- c) the security or distribution of information; and
- d) the delivery of information to the appointing party.

5.1.6 Establish the project's reference information and shared resources

The appointing party shall establish the reference information and shared resources that they intend to share with the prospective lead appointed parties during the tender process or appointment, using open data standards whenever possible to avoid duplication of effort and interoperability issues.

In doing this, the appointing party shall consider:

- a) existing asset information:
- from within the appointing party's organization;
 - from adjacent asset owners (utility companies, etc.);
 - under license from external providers (mapping and imagery, etc.); and
 - within public libraries and other sources of historical records.
- b) shared resources, for example:
- process output templates (BIM execution plan, master information delivery plan, etc.);
 - information container templates (2D/3D geometrical models, documents, etc.);
 - style libraries (lines, text and hatch, etc.); or
 - object libraries (2D symbols, 3D objects, etc.).
- c) library objects defined within national and regional standards.

NOTE The appointing party can seek support from specialist suppliers to establish reference information or shared resources.

5.1.7 Establish the project's common data environment

The appointing party shall establish (implement, configure and support) the project's common data environment (CDE) to serve the overall requirements of the project and to support the collaborative production of information (5.6).

The project's common data environment shall enable:

- a) each information container to have a unique ID, based upon an agreed and documented convention comprised of fields separated by a delimiter;
- b) each field to be assigned a value from an agreed and documented codification standard;
- c) each information container to have the following attributes assigned:
 - status (suitability);
 - revision;
 - classification (in accordance with the framework defined in [ISO 12006-2](#));
- d) the ability for information containers to transition between states;
- e) the recording of the name of user and date when information container revisions transition between each state; and
- f) controlled access at an information container level.

It is strongly recommended that the project CDE is in place prior to issuing the invitation to tender, so that information can be shared with tendering organizations in a secure manner.

The appointing party can also appoint a third-party to host, manage or support the project's CDE. In this case, it is recommended that this is done as a separate appointment before procurement of any other appointed party starts. Or the appointing party can also, at a later date, appoint an appointed party to take over the hosting, management or support of the project's CDE. In either case, it is recommended that the appointing party defines a functional and non-functional requirements specification.

5.1.8 Establish the project's information protocol

The appointing party shall establish the project's information protocol, as defined below, including any associated license agreements, which will, subsequently and appropriately, be incorporated into all appointments.

In doing this, the appointing party shall consider:

- specific obligations of the appointing party, prospective lead appointed parties and prospective appointed parties relating to the management or production of information, including the use of the project's common data environment;
- any warranties or liabilities associated to the project information model;
- background and foreground intellectual property rights of information;
- the use of existing asset information;
- the use of shared resources;
- the use of information during the project, including any associated licensing terms; and
- the re-use of information following the appointment or in the event of termination.

5.1.9 Activities for assessment and need

Activities for assessment and need are shown in [Figure 4](#).

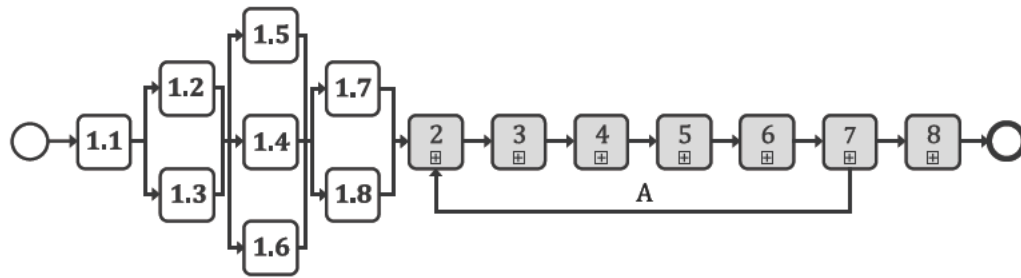

Key

- 1.1 appoint individuals to undertake the information management function
- 1.2 establish the project's information requirements
- 1.3 establish the project's information delivery milestones
- 1.4 establish the project's information standard
- 1.5 establish the project's information production methods and procedures
- 1.6 establish the project's reference information and shared resources
- 1.7 establish the project's common data environment
- 1.8 establish the project's information protocol
- A information model progressed by subsequent delivery team(s) for each appointment

NOTE Activities shown in parallel are to highlight that these activities can be undertaken concurrently and apply to all instances.

Figure 4 — Information management process — Assessment and need

5.2 Information management process — Invitation to tender

5.2.1 Establish the appointing party's exchange information requirements

The appointing party shall establish their exchange information requirements to be met by the prospective lead appointed party during the appointment.

In doing this, the appointing party shall:

- a) establish the appointing party's information requirements to be served during the appointment, and in doing so shall consider their:
 - organizational information requirements,
 - asset information requirements, and
 - project information requirements;
- b) establish the level of information need required to meet each information requirement;

NOTE Other metrics to describe the status of information, such as level of accuracy, can be added to these metrics as considered appropriate.

- c) establish the acceptance criteria for each information requirement, and in doing so shall consider:
 - the project's information standard,
 - the project's information production methods and procedures, and
 - the use of reference information or shared resources provided by the appointing party;

- d) establish the supporting information that the prospective lead appointed party might need, to fully understand or evaluate each information requirement or its acceptance criteria, and in doing so shall consider:
- existing asset information,
 - shared resources,
 - supporting documents or guidance material,
 - references to relevant international, national or industry standards, and
 - exemplars of similar information deliverables;
- e) establish the dates, relative to the project's information delivery milestones and appointing party's key decision points, that each requirement has to be met, and in doing so shall consider:
- the time needed by the appointing party to review and accept information, and
 - the appointing party's internal assurance processes.

5.2.2 Assemble reference information and shared resources

The appointing party shall assemble the reference information or shared resources that they intend to provide to the prospective lead appointed party during the tender process or appointment.

In doing this, the appointing party shall consider:

- reference information or shared resources identified during project initiation;
- information generated during previous stages of the project; and
- the suitability for which the information can be used by the prospective lead appointed party.

It is recommended that reference information and shared resources are made available to tendering organizations in a secure environment, such as the project's common data environment.

It is recommended that appointing parties identify the suitability for which the information can be used by tendering organizations and delivery teams, by way of a status code associated to each information container.

5.2.3 Establish tender response requirements and evaluation criteria

The appointing party shall establish the requirements that tendering organizations shall meet within their tender response.

In doing this, the appointing party shall consider:

- the contents of the delivery team's (pre-appointment) BIM execution plan;
- the competency of the prospective individuals undertaking the information management function on behalf of the delivery team;
- the prospective lead appointed party's assessment of the delivery team's capability and capacity;
- the delivery team's proposed mobilization plan; and
- the delivery team's information delivery risk assessment.

5.2.4 Compile invitation to tender information

The appointing party shall compile the information to be included within the invitation to tender package.

In doing this, the appointing party shall consider:

- the appointing party's exchange information requirements;
- the relevant reference information and shared resources (within the project's common data environment);
- the tender response requirements and evaluation criteria (if applicable);
- the project information delivery milestones;
- the project's information standard;
- the project's information production methods and procedure; and
- the project's information protocol.

5.2.5 Activities for invitation to tender

Activities for invitation to tender are shown in [Figure 5](#).

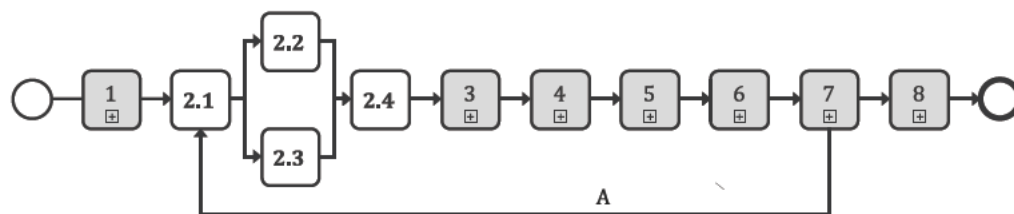

Key

- 2.1 establish the appointing party's exchange information requirements
- 2.2 assemble reference information and shared resources
- 2.3 establish tender response requirements and evaluation criteria
- 2.4 compile invitation to tender information
- A information model progressed by subsequent delivery team(s) for each appointment

NOTE Activities shown in parallel are to highlight that these activities can be undertaken concurrently.

Figure 5 — Information management process — Invitation to tender

5.3 Information management process — Tender response

5.3.1 Nominate individuals to undertake the information management function

The prospective lead appointed party shall have regard to the effective management of information throughout the appointment by nominating individuals from within its own organization to undertake the information management function on behalf of the lead appointed party.

Alternatively, the prospective lead appointed party can appoint a prospective appointed party or third party to undertake all or part of the information management function, in which case, the lead appointed party shall establish a scope of services.

In doing this, the appointing party shall consider:

- the appointing party's exchange information requirements;
- the tasks that the prospective appointed party or third party will be responsible for;
- the authority that the prospective lead appointed party will delegate to the prospective appointed party or third party;

- the competency (knowledge or skills) that the individuals undertaking the function will need; and
- probity arrangements if potential conflicts of interest may arise.

The appointing party can appoint the prospective lead appointed party to undertake all or part of the information management function on their behalf. In this scenario, to avoid any potential conflict of interest, it is recommended that individuals undertake the information management function on behalf of either the appointing party or the prospective lead appointed party.

5.3.2 Establish the delivery team's (pre-appointment) BIM execution plan

The prospective lead appointed party shall establish the delivery team's (pre-appointment) BIM execution plan, to be included within the prospective lead appointed party's tender response.

In doing this, the prospective lead appointed party shall consider:

- a) the proposed names and professional résumés of the individuals who will undertake the information management function on behalf of the delivery team;
- b) the delivery team's information delivery strategy, containing:
 - the delivery team's approach to meeting the appointing party's exchange information requirements,
 - a set of objectives/goals for the collaborative production of information,
 - an overview of the delivery team's organizational structure and commercial relationships, and
 - an overview of the delivery team's composition, in the form of one or more task teams;
- c) the proposed federation strategy to be adopted by the delivery team;
- d) the delivery team's high-level responsibility matrix, containing the allocated responsibility for each element of the information model and the key deliverables associated to each element;
- e) any proposed additions or amendments to the project's information production methods and procedures that the delivery team require to facilitate the effective:
 - capture of existing asset information,
 - generation, review, approval and authorization of information,
 - security and distribution of information, and
 - delivery of information to the appointing party;
- f) any proposed additions or amendments to the project's information standard that the delivery team require to facilitate the effective:
 - exchange of information between task teams,
 - distribution of information to external parties, or
 - delivery of information to the appointing party;
- g) a proposed schedule of software (including versions), hardware and IT infrastructure the delivery team intend to adopt.

5.3.3 Assess task team capability and capacity

Each task team shall undertake an assessment of their capability and capacity to deliver information in accordance with the appointing party's exchange information requirements and the delivery team's proposed (pre-appointment) BIM execution plan.

In doing this, each task team shall consider:

- a) the task team's capability and capacity to manage information, based upon:
 - the relevant experience and number of task team members who have managed information in accordance with the proposed information delivery strategy; and
 - the relevant education and training available to task team members;
- b) the task team's capability and capacity to produce information, based upon:
 - the relevant experience and number of task team members who have produced information in accordance with the project's information production methods and procedures; and
 - the relevant education and training available to task team members;
- c) the availability of information technology (IT) within the task team, based upon:
 - the proposed IT schedule;
 - the specification and quantity of the task team's hardware;
 - the architecture, maximum capacity and current utilization of the task team's IT infrastructure; and
 - the associated support and service level agreements available to the task team.

5.3.4 Establish the delivery team's capability and capacity

The prospective lead appointed party shall establish the delivery team's capability and capacity by aggregating the assessments undertaken by each task team to produce a summary of the delivery team's capability to manage and produce information and its capacity for timely delivery of the information.

5.3.5 Establish the delivery team's mobilization plan

The prospective lead appointed party shall establish the delivery team's proposed mobilization plan that will be initiated and implemented during mobilization (5.5).

In doing this, the prospective lead appointed party shall consider their approach, timescales and responsibilities for:

- testing and documenting the proposed information production methods and procedures;
- testing the information exchanges between task teams;
- testing the information delivery to the appointing party;
- configuring and testing the project's CDE in accordance with 5.1.7;
- configuring and testing the delivery team's (distributed) CDE and its connectivity to the project CDE (if applicable) in accordance with 5.1.7;
- procuring, implementing, configuring and testing additional software, hardware and IT infrastructure;
- developing additional shared resources to be used by the delivery team;
- developing and delivering education (knowledge required) to delivery team members;
- developing and delivering training (skills required) to the delivery team members;
- recruiting additional members of the delivery team to achieve the required capacity; and

- supporting individuals and organizations that join the delivery team during the appointment.

5.3.6 Establish the delivery team's risk register

The prospective lead appointed party shall establish the delivery team's risk register containing the risks associated with the timely delivery of information, in accordance with the appointing party's exchange information requirements, and how the delivery team intends to manage these risks.

In doing this, the prospective lead appointed party shall consider risks associated with:

- assumptions the delivery team has made in relation to the appointing party's exchange information requirements;
- meeting the appointing party's project information delivery milestones;
- the contents of the project's information protocol;
- achieving the proposed information delivery strategy;
- adopting the project's information standard and information production methods and procedures;
- inclusion (or non-inclusion) of proposed amendments to the project's information standard; and
- the mobilization of the delivery team to achieve the required capability and capacity.

NOTE The delivery team's risk register can be incorporated within other risk registers used throughout the project.

5.3.7 Compile the delivery team's tender response

The prospective lead appointed party shall compile (where available) the following items for inclusion within delivery team's tender response:

- (pre-appointment) BIM execution plan ([5.3.2](#));
- capability and capacity assessment summary ([5.3.4](#));
- mobilization plan ([5.3.5](#)); and
- information delivery risk assessment ([5.3.6](#)).

5.3.8 Activities for tender response

Activities for tender response are shown in [Figure 6](#).

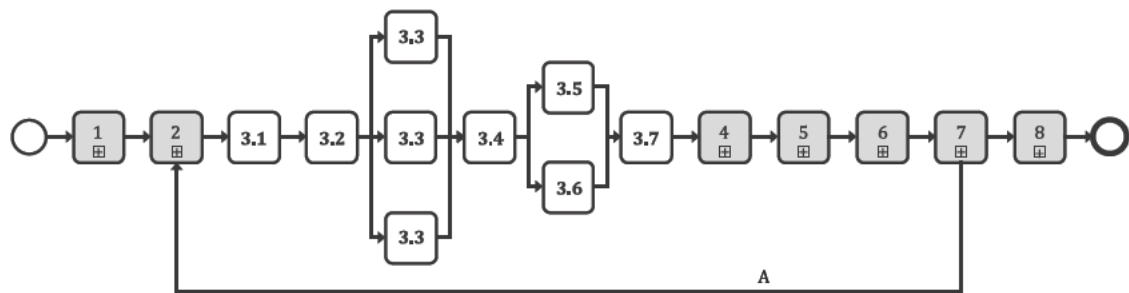

Key

- 3.1 nominate individuals to undertake the information management function
- 3.2 establish the delivery team's (pre-appointment) BIM execution plan
- 3.3 assess task team capability and capacity
- 3.4 establish the delivery team's capability and capacity
- 3.5 establish the proposed delivery team's mobilization plan
- 3.6 establish the delivery team's risk register
- 3.7 compile the delivery team's tender response
- A information model progressed by subsequent delivery team(s) for each appointment

NOTE 1 Activity 3.3 is shown multiple times to highlight that each task team needs to undertake the activity.

NOTE 2 Activities shown in parallel are to highlight that these activities can be undertaken concurrently.

Figure 6 — Information management process — Tender response

5.4 Information management process — Appointment

5.4.1 Confirm the delivery team's BIM execution plan

The lead appointed party shall confirm the delivery team's BIM execution plan in agreement with each appointed party.

In doing this, the lead appointed party shall:

- a) confirm the names of the individual(s) who will undertake the information management function within the delivery team;
- b) update the delivery team's information delivery strategy (as required);
- c) update the delivery team's high-level responsibility matrix (as required);
- d) confirm and document the delivery team's proposed information production methods and procedures;
- e) agree with the appointing party any additions or amendments to the project's information standard; and
- f) confirm the schedule of software, hardware and IT infrastructure the delivery team will use.

5.4.2 Establish the delivery team's detailed responsibility matrix

The lead appointed party shall further refine the high-level responsibility matrix to establish the detailed responsibility matrix, which identifies:

- what information is to be produced;

- when the information is to be exchanged and with whom; and
- which task team is responsible for its production.

In doing this, the lead appointed party shall consider:

- the information delivery milestones;
- the high-level responsibility matrix;
- the project's information production methods and procedures;
- the elements of information container breakdown structure allocated to each task team; and
- the dependencies on the information production process.

5.4.3 Establish the lead appointed party's exchange information requirements

The lead appointed party shall establish their exchange information requirements for each appointed party. When engaging internal teams, it is recommended that the lead appointed party establishes a clear schedule of information requirements as though it was a formal appointment.

In doing this, the lead appointed party shall:

- a) define each information requirement, and in doing so shall consider:
 - the appointing party's information requirements, which the lead appointed party requires the appointed party to meet, and
 - any additional information requirements that the lead appointed party requires the appointed party to meet;
- b) establish the level of information need required to meet each information requirement;

NOTE Other metrics to describe the status of information, such as level of accuracy, can be added to these metrics as considered appropriate.
- c) establish the acceptance criteria for each information requirement, and in doing so shall consider:
 - the project's information standard,
 - the project's information production methods and procedures, and
 - the use of reference information or shared resources provided by the appointing party or lead appointed party;
- d) establish the dates that need to be met for each requirement, relative to the project's information delivery milestones, and in doing so shall consider:
 - the time needed by the lead appointed party to review and authorize information, and
 - the lead appointed party's internal assurance processes;
- e) establish the supporting information that the appointed party might need, to fully understand or evaluate each information requirement or its acceptance criteria, and in doing so shall consider:
 - existing asset information,
 - shared resources,
 - supporting documents or guidance material,
 - references to relevant international, national or industry standards, and

- exemplars of similar information deliverables.

5.4.4 Establish the task information delivery plan(s)

Each task team shall establish, and maintain throughout its appointment, a task information delivery plan (TIDP).

In doing this, each task team shall consider:

- the project's information delivery milestones;
- the task team's responsibilities within the detailed responsibility matrix;
- the lead appointed party's information requirements;
- the availability of shared resources within the delivery team; and
- the time the task team will need to produce (generate, coordinate, review and approve) information.

The TIDP shall list and identify, for each information container:

- the name and title;
- the predecessors or dependencies;
- the level of information need;
- the (estimated) production duration;
- the information author responsible for its production; and
- the delivery milestones.

5.4.5 Establish the master information delivery plan

The lead appointed party shall aggregate the TIDP from each task team to establish the delivery team's master information delivery plan (MIDP).

In doing this, the lead appointed party shall consider:

- the assigned responsibilities within the detailed responsibility matrix;
- the information predecessors or dependencies on information between task teams;
- the time the lead appointed party will need to review and authorize the information model; and
- the time the appointing party will need to review and accept the information model.

Once the MIDP has been established, the lead appointed party shall:

- baseline the deliverables and dates within the MIDP;
- inform each task team and notify if any changes are required to the TIDP; and
- inform the appointing party of any risks or issues which could impact on the project's information delivery milestones.

5.4.6 Complete lead appointed party’s appointment documents

The appointing party shall take account of the following, in that they are included within the completed appointment documents for the lead appointed party and managed via change control throughout the duration of the appointment:

- the appointing party’s exchange information requirements;
- the project’s information standard (including any agreed additions or amendments);
- the project’s information protocol (including any agreed additions or amendments);
- the delivery team’s BIM Execution plan; and
- the delivery team’s MIDP.

5.4.7 Complete appointed party’s appointment documents

The lead appointed party shall take account of the following, in that they are included within the appointment documents for each appointed party and managed via change control throughout the duration of the appointment:

- the lead appointed party’s exchange information requirements;
- the project’s information standard (including any agreed additions or amendments) (see 5.1.4);
- the project’s information protocol (including any agreed additions or amendments);
- the delivery team’s BIM Execution plan; and
- the agreed TIDP.

5.4.8 Activities for appointment

Activities for appointment are shown in [Figure 7](#).

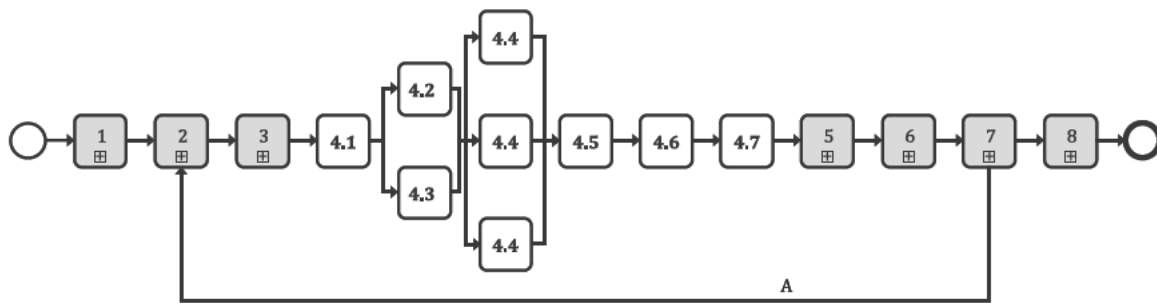

Key

- 4.1 confirm the delivery team's BIM execution plan
- 4.2 establish the delivery team’s detailed responsibility matrix
- 4.3 establish the lead appointed party’s exchange information requirements
- 4.4 establish the task information delivery plan(s)
- 4.5 establish the master information delivery plan
- 4.6 complete lead appointed party’s appointment documents
- 4.7 complete appointed party’s appointment documents
- A information model progressed by subsequent delivery team(s) for each appointment

NOTE 1 Activities shown in parallel are to highlight that these activities can be undertaken concurrently.

NOTE 2 Activity 4.4 is shown multiple times to highlight that each task team need to undertake the activity.

Figure 7 — Information management process — Appointment

5.5 Information management process — Mobilization

5.5.1 Mobilize resources

The lead appointed party shall mobilize the resources, as defined within the delivery team's mobilization plan (5.3.5).

In doing this, the lead appointed party shall:

- confirm the resource availability of each task team;
- develop and deliver education on topics such as the project's scope, exchange information requirements and delivery milestones (knowledge required) to delivery team members; and
- develop and deliver training (skills required) to the delivery team members.

5.5.2 Mobilize information technology

The lead appointed party shall mobilize the information technology, as defined within the delivery team's mobilization plan (5.3.5).

In doing this, the lead appointed party shall:

- procure, implement, configure and test software, hardware and IT infrastructure (as required);
- configure and test the project's CDE in accordance with 5.1.7;
- configure and test the delivery team's (distributed) CDE and its connectivity to the project CDE (if applicable) in accordance with 5.1.7;
- test the information exchanges between task teams; and
- test the information delivery to the appointing party.

5.5.3 Test the project's information production methods and procedures

The lead appointed party shall test the project's information production methods and procedures, as defined within the delivery team's mobilization plan (5.3.5).

In doing this, the lead appointed party shall:

- test and document the project's information production methods and procedures;
- refine and verify the proposed information container breakdown structure is workable;
- develop shared resources to be used by the delivery team; and
- communicate the project's information production methods and procedures to all tasks teams.

5.5.4 Activities for mobilization

Activities for mobilization are shown in [Figure 8](#).

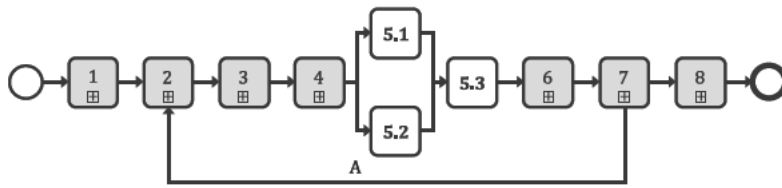

Key

- 5.1 mobilize resources
- 5.2 mobilize information technology
- 5.3 test the project’s information production methods and procedures
- A information model progressed by subsequent delivery team(s) for each appointment

NOTE Activities shown in parallel are to highlight that these activities can be undertaken concurrently.

Figure 8 — Information management process — Mobilization

5.6 Information management process — Collaborative production of information

5.6.1 Check availability of reference information and shared resources

Prior to generating information, each task team shall check that they have access to the relevant reference information and shared resources within the project’s common data environment. If not, they shall, as soon as practicable, inform the lead appointed party and assess the potential impact that this could have on the TIDP.

5.6.2 Generate information

Each task team shall generate information in accordance with their respective TIDP.

In doing this, the task team shall:

- a) generate information:
 - in compliance with the project’s information standard, and
 - in accordance with the project’s information production methods and procedures;
- b) not generate information that:
 - exceeds the required level of information need,
 - extends beyond the allocated element of the information container breakdown structure,
 - duplicates information generated by other task teams, or
 - contains superfluous detail;
- c) coordinate and cross-reference all information with information shared within the project’s common data environment, in accordance with the project’s information production methods and procedures; and
- d) spatially coordinate geometrical models with other geometrical models shared with the appropriate suitability, residing within the project’s common data environment.

In the event of a coordination issue, the relevant task teams shall collaborate to identify a possible resolution. If a resolution cannot be found the task teams shall notify the lead appointed party.

5.6.3 Undertake quality assurance check

Each task team shall undertake a quality assurance check of each information container, in accordance with the project's information production methods and procedures, prior to undertaking a review of the information within it (5.6.4).

In doing this, the task team shall check the information container in accordance with the project's information standard.

Once the check is complete, the task team shall:

- a) if the check is successful:
 - mark the information container as checked, and
 - record the outcome of the check; or
- b) if the check is unsuccessful:
 - reject the information container, and
 - inform the information author of the outcome and corrective action required.

NOTE 1 It could be possible for checks to be automated within the project's common data environment

NOTE 2 A compliance check does not check the accuracy or appropriateness of the information within the information container and therefore cannot be seen as a replacement for review and approval (5.6.4).

5.6.4 Review information and approve for sharing

In accordance with the project's information production methods and procedures, each task team shall undertake a review of the information within the information container prior to sharing within the project's common data environment.

In doing this, the task team shall consider:

- the lead appointed party's information requirements;
- the level of information need; and
- information needed for coordination by other task teams.

Once the review is complete, the task team shall:

- a) if the review is successful:
 - assign the suitability for which the information contained within the information container can be used, and
 - approve the information container for sharing;
- b) if the review is unsuccessful:
 - record why the review was unsuccessful,
 - record any amendments for the task team to complete, and
 - reject the information container.

5.6.5 Information model review

The delivery team shall undertake a review of the information model, in accordance with the project’s information production methods and procedures, to facilitate the continuous coordination of information across each element of the information model.

In doing this, the delivery team shall consider:

- the appointing party’s information requirements and acceptance criteria; and
- the information containers listed within the master information delivery plan.

5.6.6 Activities for collaborative production of information

Activities for collaborative production of information are shown in [Figure 9](#).

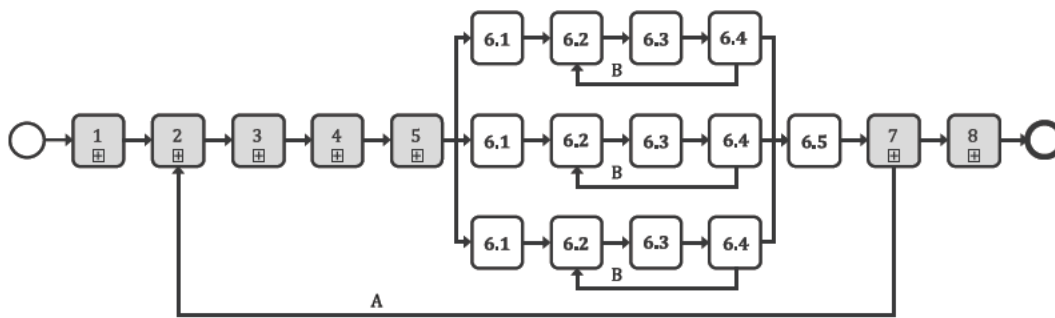

Key

- 6.1 check availability of reference information and shared resources
- 6.2 generate information
- 6.3 complete quality assurance check
- 6.4 review information and approve for sharing
- 6.5 information model review
- A information model progressed by subsequent delivery team(s) for each appointment
- B new information container revision

NOTE 1 Activities shown in parallel highlight the production of information by each task team prior to the information model review.

NOTE 2 The information model review undertaken in 6.5 can be repeated until such time as the information model is ready to be submitted for lead appointed party authorization.

Figure 9 — Information management process — Collaborative production of information

5.7 Information management process — Information model delivery

5.7.1 Submit information model for lead appointed party authorization

Prior to the delivery of the information model to the appointing party, each task team shall submit their information to the lead appointed party for authorization within the project’s common data environment.

5.7.2 Review and authorize the information model

The lead appointed party shall undertake a review of the information model in accordance with the project’s information production methods and procedures.

In doing this, the lead appointed party shall consider:

- the deliverables listed in the master information delivery plan;
- the appointing party's exchange information requirements;
- the lead appointed party's exchange information requirements;
- the acceptance criteria for each information requirement; and
- the level of information need for each information requirement.

If the review is successful, the lead appointed party shall authorize the information model and instruct each task team to submit their information for appointing party acceptance within the project's common data environment.

If the review is unsuccessful, the lead appointed party shall reject the information model and instruct the task teams to amend the information and re-submit for lead appointed party authorization.

Partial acceptance of the information to be exchanged (as defined within the MIDP) can lead to coordination issues, therefore it is recommended that the lead appointed party either authorizes or rejects the entire information model.

5.7.3 Submit information model for appointing party acceptance

Each task team shall submit their information for appointing party review and acceptance within the project's common data environment.

5.7.4 Review and accept the information model

The appointing party shall undertake a review of the information model in accordance with the project's information production methods and procedures.

In doing this, the appointing party shall consider:

- the deliverables listed in the master information delivery plan;
- the appointing party's exchange information requirements;
- the acceptance criteria for each information requirement; and
- the level of information need for each information requirement.

If the review is successful, the appointing party shall accept the information model as a deliverable within the project's common data environment.

If the review is unsuccessful, the appointing party shall reject the information model and instruct the lead appointed party to amend the information and re-submit for appointing party's acceptance.

Partial acceptance of the information to be exchanged (as defined within the MIDP) can lead to coordination issues, therefore it is recommended that the appointing party either accepts or rejects the entire information model.

5.7.5 Activities for information model delivery

Activities for information model delivery are shown in [Figure 10](#).

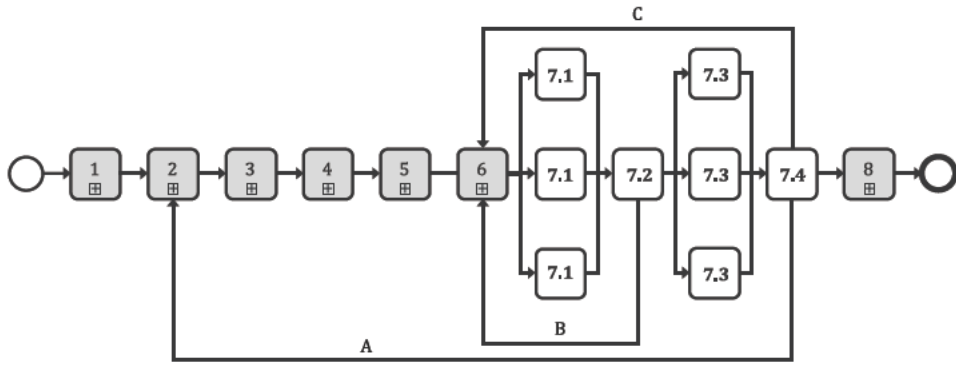

Key

- 7.1 submit information model for lead appointed party authorization
- 7.2 review and authorize the information model
- 7.3 submit information model for appointing party acceptance
- 7.4 review and accept the information model
- A information model progressed by subsequent delivery team(s) for each appointment
- B information model rejected by lead appointed party
- C information model rejected by appointing party

Figure 10 — Information management process — Information model delivery

5.8 Information management process — Project close-out

5.8.1 Archive the project information model

Upon acceptance of the completed project information model, the appointing party shall archive the information containers within the project’s common data environment in accordance with the project’s information production methods and procedures.

In doing this, the appointing party shall consider:

- which information containers will be needed as part of the asset information model;
- future access requirements;
- future re-use; and
- relevant retention policies to be applied.

5.8.2 Capture lessons learned for future projects

In collaboration with each lead appointed party, the appointing party shall capture lessons learned during the project and record them in a suitable knowledge store, to be called upon by future projects.

It is recommended that lessons learned are captured throughout the entire project.

5.8.3 Activities for project close-out

Activities for project close-out are shown in [Figure 11](#).

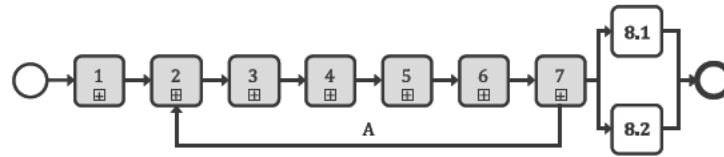

Key

8.1 archive the project information model

8.2 compile lessons learned for future projects

A information model progressed by subsequent delivery team(s) for each appointment

NOTE Activities shown in parallel are to highlight that these activities can be undertaken concurrently.

Figure 11 — Information management process — Project close-out

Annex A (informative)

Information management assignment matrix

Table A.1 — Information management responsibility matrix template

ID	Key	Appointing party	Third party	Lead appointed party	Appointed party
	R Responsible for undertaking activity A Accountable for activity completion C Consulted during activity I Informed following activity completion Task				
5.1.1	Appoint individuals to undertake the information management function				
5.1.2	Establish the project's information requirements				
5.1.3	Establish the project's information delivery milestones				
5.1.4	Establish the project's information standard				
5.1.5	Establish the project's information production methods and procedures				
5.1.6	Establish the project's reference information and shared resources				
5.1.7	Establish the project's common data environment				
5.1.8	Establish the project's information protocol				
5.2.1	Establish the appointing party's exchange information requirements				
5.2.2	Assemble reference information and shared resources				
5.2.3	Establish tender response requirements and evaluation criteria				
5.2.4	Compile invitation to tender information				
5.3.1	Nominate individuals to undertake the information management function				
5.3.2	Establish the delivery team's (pre-appointment) BIM execution plan				
5.3.3	Assess each task team capability and capacity				
5.3.4	Establish the delivery team's capability and capacity				
5.3.5	Establish the delivery team's mobilization plan				
5.3.6	Establish the delivery team's risk register				
5.3.7	Compile the delivery team's tender response				
5.4.1	Confirm the delivery team's BIM execution plan				
5.4.2	Establish the delivery team's detailed responsibility matrix				

Table A.1 (continued)

ID	Key R Responsible for undertaking activity A Accountable for activity completion C Consulted during activity I Informed following activity completion Task	Appointing party	Third party	Lead appointed party	Appointed party
5.4.3	Establish the lead appointed party's exchange information requirements				
5.4.4	Establish the task information delivery plan(s)				
5.4.5	Establish the master information delivery plan				
5.4.6	Complete lead appointed party's appointment documents				
5.4.7	Complete appointed party's appointment documents				
5.5.1	Mobilize resources				
5.5.2	Mobilize information technology				
5.5.3	Test the project's information production methods and procedures				
5.6.1	Check availability of reference information and shared resources				
5.6.2	Generate information				
5.6.3	Undertake quality assurance check				
5.6.4	Review information and approve for sharing				
5.6.5	Information model review				
5.7.1	Submit information model for lead appointed party authorization				
5.7.2	Review and authorize the information model				
5.7.3	Submit information model for appointing party acceptance				
5.7.4	Review and accept the information model				
5.8.1	Archive the project information model				
5.8.2	Capture lessons learned for future projects				

Bibliography

- [1] ISO 6707-2:2017, *Buildings and civil engineering works — Vocabulary — Part 2: Contract and communication terms*
- [2] [ISO/IEC 19510](#), *Information technology — Object Management Group Business Process Model and Notation*
- [3] [ISO 21500](#), *Guidance on project management*
- [4] [ISO 22263:2008](#), *Organization of information about construction works — Framework for management of project information*
- [5] [ISO 55000](#), *Asset management — Overview, principles and terminology*

National Annex NA (informative)

National Annex to BS EN ISO 19650-2:2018

NA.1 General

The role of a National Annex to a standard is to clarify its implementation within a country, but it should not preclude international cooperation and agreement.

A National Annex should clarify any regional, language or country-specific usage. For international collaborative projects, an international or a specific National Annex may be selected.

This National Annex will assist the user in understanding the UK implementation of this standard by translating the key terms and expanding on the requirements.

NA.2 Information container identification (ID)

NA.2.1 Clarification

ISO 19650-2:2018 (5.1.7.a) states: 'The project's common data environment shall enable each information container to have a unique ID, based upon an agreed and documented convention [comprising] fields separated by a delimiter'.

NA.2.2 Information containers

In the UK, the unique ID for information containers within a common data environment should be defined using the following fields, separated by a delimiter, in accordance with the following convention.

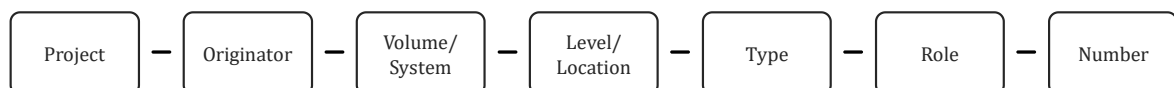

Figure NA.1 — Identification of information containers within a common data environment

NOTE If an information container is removed or exported from the common data environment, then the additional fields 'suitability' and 'revision', separated by a delimiter, should be added to its ID as a suffix.

NA.2.3 Delimiters

In the UK, the following delimiter is to be used.

Hyphen-Minus Unicode Reference U+002D

NA.3 Field codification

NA.3.1 Clarification

ISO 19650-2:2018 (5.1.7.b) states: 'The project's common data environment shall enable each field to be assigned a value from an agreed and documented codification standard'.

In the UK, the codification for each field should be defined from the following codifications.

NA.3.2 Project

A single common project identifier should be defined at the initiation of the project. It should be independent and recognizably distinct from any individual organization's internal job number and be fixed within the project information standard. It is recommended that the code for the project field be between two and six characters in length.

NOTE 1 There are no standard codes for the project field.

NOTE 2 A project can be divided into sub-projects.

NOTE 3 Where a project involves several elements or one element with several phases, each element or phase can be assigned an identifier.

NA.3.3 Originator

A unique identifier should be defined for each organization on joining the project, to identify the organization responsible for producing the information within the container, and fixed within the project information standard. It is recommended that the code for the originator field be between three and six characters in length.

NOTE Where a project involves several elements or one element with several phases, each element or phase can be assigned an identifier.

NA.3.4 Volume/System

A unique identifier should be defined for each volume/system and fixed within the project information standard. It is recommended that the code for the volume/system field be two characters in length.

The following standard codes should apply.

ZZ all volumes/systems

XX no volume/system applicable

NOTE This list can be expanded with project-specific codes.

NA.3.5 Level/Location

A unique identifier should be defined for each level/location and fixed within the project information standard. It is recommended that the code for level/location field be two characters in length.

The following standard codes should apply.

ZZ multiple levels/locations

XX no level/location applicable

00 base level

01 level 01

02 level 02, etc.

M1 mezzanine above level 01

M2 mezzanine above level 02, etc.

B1 basement level 1

B2 basement level 2, etc.

NOTE 1 This list can be expanded with project-specific codes.

NOTE 2 The location codes for assets other than buildings are likely to require project-specific codes.

NA.3.6 Type

A unique identifier should be defined for each type of information, to identify the type of information held within the information container, and fixed within the project information standard. It is recommended that the code for the type field be two characters in length.

The following standard codes should apply.

AF	animation file (of a model)
BQ	bill of quantities
CA	calculations
CM	combined model (combined multidiscipline model)
CO	correspondence
CP	cost plan
CR	clash rendition
DB	database
DR	drawing rendition
FN	file note
HS	health and safety
IE	information exchange file
M2	2D model
M3	3D model
MI	minutes / action notes
MR	model rendition for other renditions, e.g. thermal analysis, etc.
MS	method statement
PP	presentation
PR	programme
RD	room data sheet
RI	request for information
RP	report
SA	schedule of accommodation
SH	schedule

SN	snagging list
SP	specification
SU	survey
VS	visualization

NOTE This list can be expanded with project-specific codes.

NA.3.7 Role

A unique identifier should be defined for each role on the project that an organization is assigned and fixed within the project information standard. It is recommended that the code for the role field be one or two characters in length.

The following standard codes should apply.

A	architect
B	building surveyor
C	civil engineer
D	drainage, highways engineer
E	electrical engineer
F	facilities manager
G	geographical and land surveyor
H	heating and ventilation designer (deprecated)
I	interior designer
K	client
L	landscape architect
M	mechanical engineer
P	public health engineer
Q	quantity surveyor
S	structural engineer
T	town and country planner
W	contractor
X	subcontractor
Y	specialist designer
Z	general (non-disciplinary)

NOTE This list can be expanded with two character project-specific codes.

NA.3.8 Number

A sequential number should be assigned to each information container when it is one of a series, not distinguished by any other of the fields.

The numbering for standard coding should be fixed within the project information standard and it is recommended that it be between four and six integer numeric digits in length.

NOTE Leading zeros should be used and care should be taken not to embody information that is present in other fields.

NA.4 Information container metadata

NA.4.1 Clarification

ISO 19650-2:2018 (5.1.7.c) states: 'The project's common data environment shall enable each information container to have the following attributes [metadata] assigned: status (suitability); revision; classification (in accordance with the framework defined in ISO 12006-2)'.

In the UK, attributes (metadata) for information containers within a common data environment should be defined from the following codification table.

NA.4.2 Status

Table NA.1 — Status codes for information containers within a common data environment

Code	Description	Revision
Work in progress (WIP)		
S0	Initial status	Preliminary revision and version
Shared (non-contractual)		
S1	Suitable for coordination	Preliminary revision
S2	Suitable for information	Preliminary revision
S3	Suitable for review and comment	Preliminary revision
S4	Suitable for stage approval	Preliminary revision
S5	Withdrawn	N/A
S6	Suitable for PIM authorization	Preliminary revision
S7	Suitable for AIM authorization	Preliminary revision
Published (contractual)		
A1, An, etc.	Authorized and accepted	Contractual revision
B1, Bn, etc.	Partial sign-off (with comments)	Preliminary revision
Published (for AIM acceptance)		
CR	As constructed record document	Contractual revision

NOTE 1 'n' relates to the work stages defined within BS 8536-1:2015 and BS 8536-2:2016.

NOTE 2 This list can be expanded for project-specific codes and fixed within the project information standard.

NA.4.3 Revision

Preliminary revisions of information containers should be two integers, prefixed with the letter 'P', e.g. P01.

Preliminary revisions of information containers in the 'work in progress' state should also have a two integer suffix to identify the version of the preliminary revision, e.g. P02.05.

The initial revision of information containers should be P01.01.

Contractual revisions of information containers should be two integers, prefixed with the letter 'C', e.g. C01.

NA.4.4 Classification

Classification of information within information containers should be in accordance with Uniclass 2015 (the UK implementation of [ISO 12006-2:2018](#)).

NA.5 Information model exchange

NA.5.1 Clarification

ISO 19650-2:2018 [\(5.2.1\)](#) states: 'The appointing party shall establish their exchange information requirements to be met by the prospective lead appointed party during the appointment.'

In the UK, information models exchanged with the appointing party, unless specified to the contrary within the project information standard, should include:

- a) geometrical information in proprietary formats or open data formats;
- b) non-geometrical information in open data formats, structured in accordance with BS 1192-4:2014 (COBie) and contained within a single information container; and
- c) documentation in open data formats.

NOTE 1 Open data formats recommended for information containers containing geometrical information include [ISO 16739](#) (IFC) schema files in ISO 10303-21 and ISO 10303-28 (second edition).

NOTE 2 Open data formats recommended for information containers containing non-geometrical information include ISO/IEC 29500-1 (xlsx) and [ISO 16739](#) (IFC) schema files in ISO 10303-21 or ISO 10303-28 (second edition).

NOTE 3 Open data formats recommended for information containers containing documentation include those in ISO 32000-1 and ISO 32000-2 (PDF).

NA.6 Project's information requirements

NA.6.1 Clarification

ISO 19650-2:2018 [\(5.1.2\)](#) states: 'The appointing party shall establish the project's information requirements, as described in ISO 19650-1:2018 (5.3), to address the questions to which the appointing party needs answer(s) at each of the key decision points throughout the project.'

In the UK, the appointing party's defined information exchange points (key decision points) within each of the principal work stages (see [BS 8536-1:2015](#) or BS 8563-2:2016) are to be used in defining the project's information requirements.

British Standards Institution (BSI)

BSI is the national body responsible for preparing British Standards and other standards-related publications, information and services.

BSI is incorporated by Royal Charter. British Standards and other standardization products are published by BSI Standards Limited.

About us

We bring together business, industry, government, consumers, innovators and others to shape their combined experience and expertise into standards-based solutions.

The knowledge embodied in our standards has been carefully assembled in a dependable format and refined through our open consultation process. Organizations of all sizes and across all sectors choose standards to help them achieve their goals.

Information on standards

We can provide you with the knowledge that your organization needs to succeed. Find out more about British Standards by visiting our website at bsigroup.com/standards or contacting our Customer Services team or Knowledge Centre.

Buying standards

You can buy and download PDF versions of BSI publications, including British and adopted European and international standards, through our website at bsigroup.com/shop, where hard copies can also be purchased.

If you need international and foreign standards from other Standards Development Organizations, hard copies can be ordered from our Customer Services team.

Copyright in BSI publications

All the content in BSI publications, including British Standards, is the property of and copyrighted by BSI or some person or entity that owns copyright in the information used (such as the international standardization bodies) and has formally licensed such information to BSI for commercial publication and use.

Save for the provisions below, you may not transfer, share or disseminate any portion of the standard to any other person. You may not adapt, distribute, commercially exploit, or publicly display the standard or any portion thereof in any manner whatsoever without BSI's prior written consent.

Storing and using standards

Standards purchased in soft copy format:

- A British Standard purchased in soft copy format is licensed to a sole named user for personal or internal company use only.
- The standard may be stored on more than 1 device provided that it is accessible by the sole named user only and that only 1 copy is accessed at any one time.
- A single paper copy may be printed for personal or internal company use only.
- Standards purchased in hard copy format:
 - A British Standard purchased in hard copy format is for personal or internal company use only.
 - It may not be further reproduced – in any format – to create an additional copy. This includes scanning of the document.

If you need more than 1 copy of the document, or if you wish to share the document on an internal network, you can save money by choosing a subscription product (see 'Subscriptions').

Reproducing extracts

For permission to reproduce content from BSI publications contact the BSI Copyright & Licensing team.

Subscriptions

Our range of subscription services are designed to make using standards easier for you. For further information on our subscription products go to bsigroup.com/subscriptions.

With **British Standards Online (BSOL)** you'll have instant access to over 55,000 British and adopted European and international standards from your desktop. It's available 24/7 and is refreshed daily so you'll always be up to date.

You can keep in touch with standards developments and receive substantial discounts on the purchase price of standards, both in single copy and subscription format, by becoming a **BSI Subscribing Member**.

PLUS is an updating service exclusive to BSI Subscribing Members. You will automatically receive the latest hard copy of your standards when they're revised or replaced.

To find out more about becoming a BSI Subscribing Member and the benefits of membership, please visit bsigroup.com/shop.

With a **Multi-User Network Licence (MUNL)** you are able to host standards publications on your intranet. Licences can cover as few or as many users as you wish. With updates supplied as soon as they're available, you can be sure your documentation is current. For further information, email subscriptions@bsigroup.com.

Revisions

Our British Standards and other publications are updated by amendment or revision.

We continually improve the quality of our products and services to benefit your business. If you find an inaccuracy or ambiguity within a British Standard or other BSI publication please inform the Knowledge Centre.

Useful Contacts

Customer Services

Tel: +44 345 086 9001

Email (orders): orders@bsigroup.com

Email (enquiries): cservices@bsigroup.com

Subscriptions

Tel: +44 345 086 9001

Email: subscriptions@bsigroup.com

Knowledge Centre

Tel: +44 20 8996 7004

Email: knowledgecentre@bsigroup.com

Copyright & Licensing

Tel: +44 20 8996 7070

Email: copyright@bsigroup.com

BSI Group Headquarters

389 Chiswick High Road London W4 4AL UK